

PA BY-PASS TEE

OPERATING INSTRUCTIONS

1. Mounting surface must be clean and free of cuts and scratches.
2. Place top half of the saddle on the main. Place the bottom half of the saddle on the main with the holes lined up to insert the bolts. Insert all bolts and start the threads. Tighten two center bolts first using care to pull the saddle down evenly by tightening alternately front and back bolts, taking care not to rotate saddle on main. Do not move saddle after bolts are started. Tighten remaining bolts evenly until flanges of saddle come together.

COMPRESSION OUTLET INSTRUCTIONS

1. Stop the flow prior to installing compression outlet on live services. (See "TAPPING MAIN" instructions below)
2. For compression type outlets see other side for assembly instructions.

DEAD END OUTLET ASSEMBLY INSTRUCTIONS

1. Stop flow prior to installing dead end outlet on live services. (See "TAPPING MAIN" instructions below)
2. Remove existing outlet components.
3. Install dead end nut as shown below tightening dead end nut until it shoulders against outlet. **Do not over tighten.**

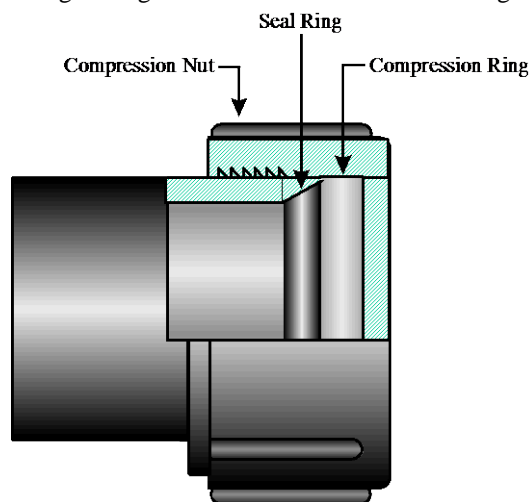

TAPPING MAIN

1. Remove cap and install valve adapter (for 1-1/4" IPS outlets use 33-4916-00 and for 2" IPS outlets use 33-4625-00). Follow tapping equipment manufacturer's instructions on tapping and plugging main.

COMPLETION INSTRUCTIONS

1. Ensure that the completion plug and o-ring are lubricated and free from any dirt, chips, etc.
2. Follow the tapping and plugging manufacture's instructions and insert the completion plug into the top of the tee tower ensuring the threads are aligned correctly. Rotate the completion plug clockwise approximately 8 full turns or flush with top of the tee tower to seat the completion plug into the By-Pass Tee. **Do Not Over Tighten.**
3. Replace the cap. Tighten the cap 1/4 turn past hand tight.

IMPORTANT

For use on:

Thermoplastic gas pipe meeting the requirements of ASTM D 2513

Pressure Rating: Designed to meet or exceed pressure rating of PE pipe per 49 CFR Part 192 and ASTM D 2513

Operating Temperature: -20 to 140°F

ASSEMBLY INSTRUCTIONS FOR 1-1/4" IPS AND 2" IPS COMPRESSION OUTLETS

1. Clean pipe ends. The pipe ends should be undamaged and squarely cut. Deburr inside of pipe ends if necessary.
2. Inspect the pipe to ensure that there are no cuts or gouges located in the sealing area of the pipe.
3. Mark the maximum stab depth (see example for correct pipe size and corresponding stab depth) from the end of the pipe.

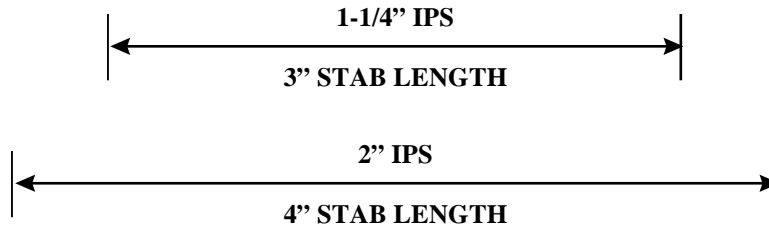

4. Remove the red cap plug and stiffener from end of outlet without removing the compression nut (discard the cap plug). Tap the stiffener into the pipe until the ID of the pipe rests on the knurl of the stiffener.
NOTE: If protective sleeve is required, slip it over pipe now, before making up outlet.
5. Stab the pipe into outlet up to (not past) the stab mark. (When stabbing the pipe, the compression nut should be loosened to the point that at least three to five threads are showing). See figure 1.

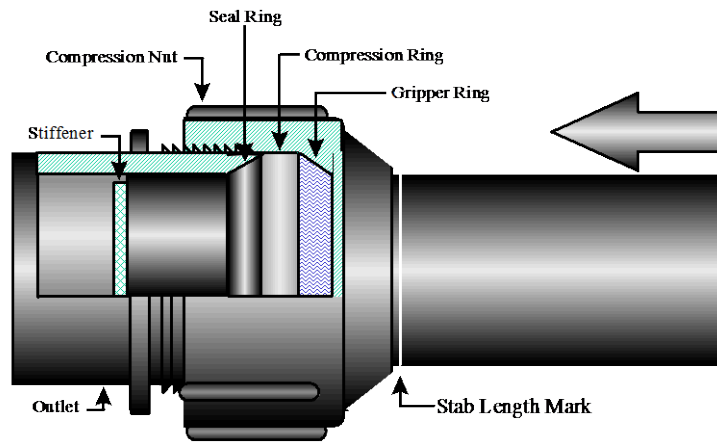

Figure 1

6. Tighten the compression nut until it shoulders against the body of the outlet. **Do Not Over Tighten.** If you cannot see the stab mark or the end of the compression nut is not within the distances listed below, reassemble the fitting. See figure 2.
7. Maximum distance from the end of the compression nut to the stab marks are shown below:

Pipe Size (Inches)	Maximum Distance (Inches)
1-1/4	5/8
2	1

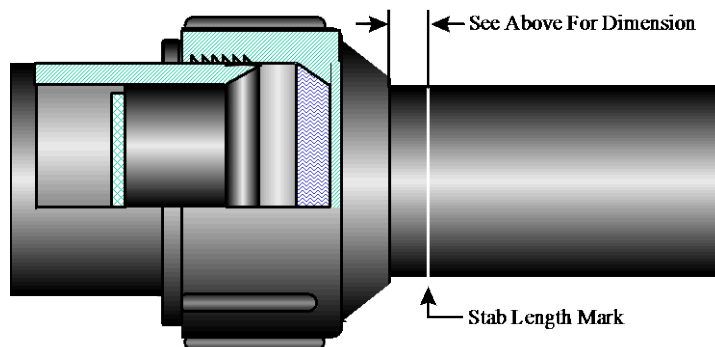

Figure 2

NOTE: It is advisable to limit shear at main connections. In this regard, your company's policies should be followed. For further information, reference; ASTM D 2774 Standard Practice for Underground Installation of Thermoplastic Pressure Piping; Code of Federal Regulations, Title 49, Transportation Part 192; AGA Plastic Pipe Manual and/or The Guidance Manual for Operators of Small Gas Systems by the U.S. Department of Transportation.